

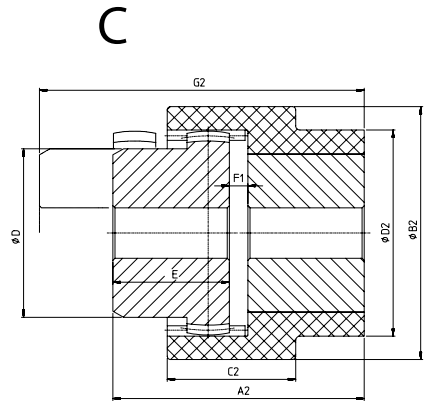

A



B



C

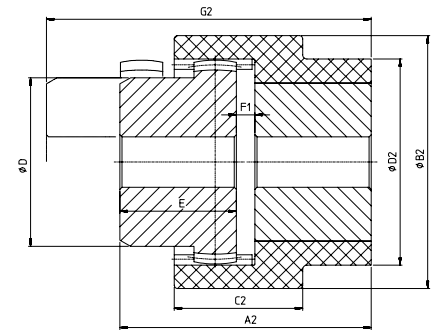
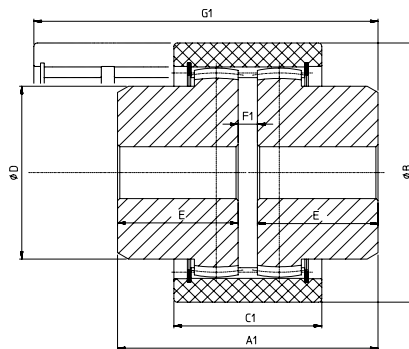
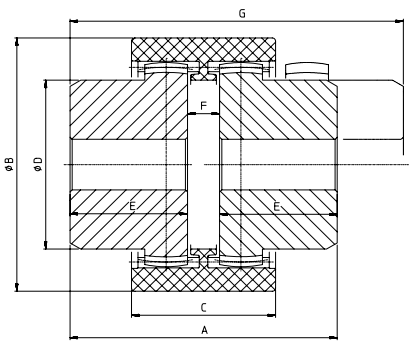

Type 20/24 : Nylon

Type 28/42 : Zamak
Zinc alloy

Type 60 : Acier, Staal, Steel, Stahl

DIN 1743/2 : GD - Zn A 14
AFNOR A55-010 : Z - A 4G
BS 1004 : A
ASTM B86 (64) : AG 40 A



| Type | | | t = 60° C max. Nm | tr/min omw/min rpm - min ⁻¹ | J (WR ²) (kgm ²) | (°) max. | (mm) max. | (mm) max. | kg | A (mm) | A1 (mm) | A2 (mm) |
|------|--------------|--------------|--------------------------|--|--|-----------------|------------------|------------------|--------|-----------|------------|------------|
| | max. (mm) | min. (mm) | | | | | | | | | | |
| 20 | 20 | 6 | 13 | 6000 | 0,00001 | 3,0 | 0,4 | 6 | 0,07 | 50 | — | — |
| 24 | 24 | 8 | 20 | 6000 | 0,00004 | 3,0 | 0,4 | 6 | 0,10 | 56 | — | — |
| 28 | 28 | 9 | 40 | 5000 | 0,00020 | 3,0 | 0,5 | 6 | 0,70 | 65 | 60 | — |
| 28C | 28 | 9 | 40 | 5000 | 0,00020 | 1,5 | 0,05 | 6 | 0,68 | — | — | 60 |
| 42 | 42 | 11 | 80 | 5000 | 0,00100 | 3,0 | 0,6 | 8 | 1,80 | 96 | 86 | — |
| 60 | 60 | 25 | 300 | 4000 | 0,00690 | 3,0 | 0,9 | 6 | 7,77 | 125 | 125 | — |

| Type | B (mm) | B2 (mm) | C (mm) | C1 (mm) | C2 (mm) | D (mm) | D2 (mm) | E (mm) | E2 (mm) | F (mm) | F1 (mm) | F2 (mm) | G (mm) | G1 (mm) | G2 (mm) |
|------|-----------|------------|-----------|------------|------------|-----------|------------|-----------|------------|-----------|------------|------------|-----------|------------|------------|
| 20 | 46 | — | 33 | — | — | 32,0 | — | 22,0 | — | 6 | — | — | 65 | — | — |
| 24 | 54 | — | 35 | — | — | 38,0 | — | 25,0 | — | 6 | — | — | 71 | — | — |
| 28 | 73 | — | 36 | 33,5 | — | 44,5 | — | 28,5 | — | 8 | 3,0 | — | 80 | 65 | — |
| 28C | — | 68 | — | — | 27 | 44,5 | 56 | 28,5 | 28,5 | — | — | 3 | — | — | 76 |
| 42 | 95 | — | 51 | 47,6 | — | 60,0 | — | 41,3 | — | 13 | 3,2 | — | 116 | 95 | — |
| 60 | 120 | — | 67 | 67,0 | — | 80,0 | — | 60,0 | — | 5 | 5,0 | — | 160 | 160 | — |

Consult our complete coupling program on: www.escocoupling.com